

Approved ADSL Broadband Filter

Lifeline home units are compatible with ADSL broadband internet connections in order to allow users to benefit from fast internet provision without affecting their safety and security.

In order to provide a broadband connection in a dwelling with a Lifeline unit, an ADSL filter is plugged into the main telephone socket of the home. The filter provides two separate sockets to allow connection of the Lifeline home unit and a computer.

Under normal circumstances, the connection of the Lifeline unit to the filter will not affect operation however, if the filter is of a very poor quality, an alarm call from **any** social alarm connected to it could be adversely affected.

In order to prevent this risk, Tunstall has taken the step of fully testing and approving a high quality ADSL filter which provides complete peace of mind each time a unit is installed in a home with a broadband internet connection.

The filter can be used in applications where single computers are connected to broadband or even where a computer network exists – please see the following connection diagrams.

Single PC Connection (typical domestic application)

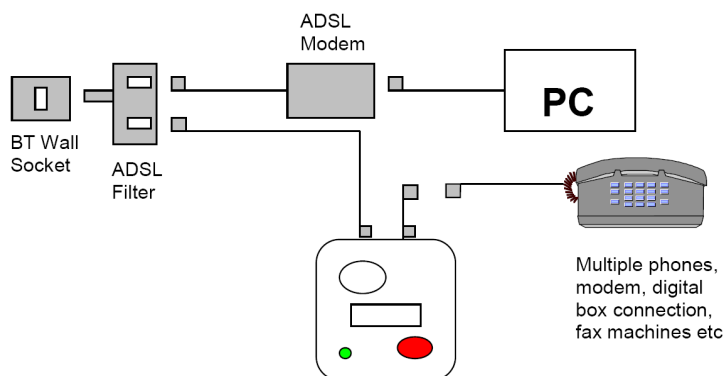

Networked PC Connection

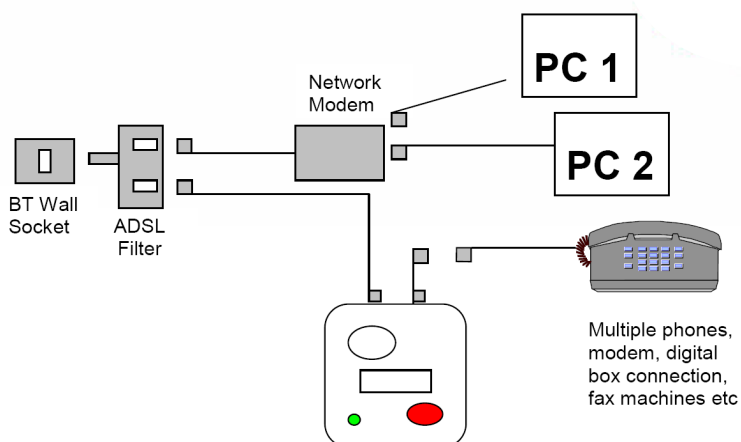

Please call 01977 660479 to order your filter.

Part number: S1908007